

Compact Guide Cylinder

Series **MGP**

ø12, ø16, ø20, ø25, ø32,
ø40, ø50, ø63, ø80, ø100

Features

- ➔ Four mounting types provided as standard.
- ➔ Piping is possible from two directions.
- ➔ Two types of guide rod bearing to accommodate various applications:
 - Slide bearing
 - Ball bushing
- ➔ Auto switches can be mounted on two sides.
- ➔ Guides integrated into body.
- ➔ Saves space and time compared to external guides.



Specifications

Action	Double acting	
Fluid	Air	
Proof pressure	1.5 MPa	
Maximum operating pressure	1.0 MPa	
Minimum operating pressure	ø12, ø16	0.12 MPa
	ø20 to ø100	0.1 MPa
Ambient and fluid temperature	-10 to 60°C (No freezing)	
Piston speed ^{Note)}	ø12 to ø63	50 to 500 mm/s
	ø80, ø100	50 to 400 mm/s
Cushion	Rubber bumper on both ends	
Lubrication	Non-lube	
Stroke length tolerance	+1.5 0 mm	

Note) Maximum speed with no load.
Make a model selection, considering a load according to the graph, see single catalogue.

How to Order

MGP M 25 TF — 30

Bearing type

M	Slide bearing
L	Ball bushing bearing

Bore size

12	12 mm	40	40 mm
16	16 mm	50	50 mm
20	20 mm	63	63 mm
25	25 mm	80	80 mm
32	32 mm	100	100 mm

Thread type

Nil	M5 (ø12, 16)
TF	G (ø20 to ø100)

• Cylinder stroke (mm)

Bore size (mm)	Standard stroke (mm)
12, 16	10, 20, 30, 40, 50, 75, 100, 125, 150, 175, 200, 250
20, 25	20, 30, 40, 50, 75, 100, 125, 150, 175, 200, 250, 300, 350, 400
32 to 100	25, 50, 75, 100, 125, 150, 175, 200, 250, 300, 350, 400

➔ Auto Switch Specifications
Refer to switch section.



Allowable Rotational Torque of Plate

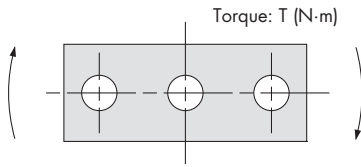

Non-rotating Accuracy of Plate

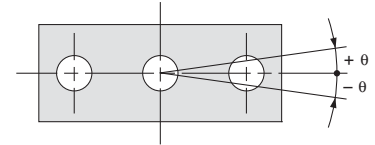

For non-rotating accuracy without load, use a value no more than the values in the table as a guide.

T (N-m)

Bore size (mm)	Bearing type	Stroke (mm)															
		10	20	25	30	40	50	75	100	125	150	175	200	250	300	350	400
12	MGPM	0.39	0.32	—	0.27	0.24	0.21	0.43	0.36	0.31	0.27	0.24	0.22	0.19	—	—	—
	MGPL	0.61	0.45	—	0.35	0.58	0.50	0.37	0.29	0.24	0.20	0.18	0.16	0.12	—	—	—
16	MGPM	0.69	0.58	—	0.49	0.43	0.38	0.69	0.58	0.50	0.44	0.40	0.36	0.30	—	—	—
	MGPL	0.99	0.74	—	0.59	0.99	0.86	0.65	0.52	0.43	0.37	0.32	0.28	0.23	—	—	—
20	MGPM	—	1.05	—	0.93	0.83	0.75	1.88	1.63	1.44	1.28	1.16	1.06	0.90	0.78	0.69	0.62
	MGPL	—	1.26	—	1.03	2.17	1.94	1.52	1.25	1.34	1.17	1.03	0.93	0.76	0.65	0.56	0.49
25	MGPM	—	1.76	—	1.55	1.38	1.25	2.96	2.57	2.26	2.02	1.83	1.67	1.42	1.24	1.09	0.98
	MGPL	—	2.11	—	1.75	3.37	3.02	2.38	1.97	2.05	1.78	1.58	1.41	1.16	0.98	0.85	0.74
32	MGPM	—	—	6.35	—	—	5.13	5.69	4.97	4.42	3.98	3.61	3.31	2.84	2.48	2.20	1.98
	MGPL	—	—	5.95	—	—	4.89	5.11	4.51	6.34	5.79	5.33	4.93	4.29	3.78	3.38	3.04
40	MGPM	—	—	7.00	—	—	5.66	6.27	5.48	4.87	4.38	3.98	3.65	3.13	2.74	2.43	2.19
	MGPL	—	—	6.55	—	—	5.39	5.62	4.96	6.98	6.38	5.87	5.43	4.72	4.16	3.71	3.35
50	MGPM	—	—	13.0	—	—	10.8	12.0	10.6	9.50	8.60	7.86	7.24	6.24	5.49	4.90	4.43
	MGPL	—	—	9.17	—	—	7.62	9.83	8.74	11.6	10.7	9.83	9.12	7.95	7.02	6.26	5.63
63	MGPM	—	—	14.7	—	—	12.1	13.5	11.9	10.7	9.69	8.86	8.16	7.04	6.19	5.52	4.99
	MGPL	—	—	10.2	—	—	8.48	11.0	9.74	13.0	11.9	11.0	10.2	8.84	7.80	6.94	6.24
80	MGPM	—	—	21.9	—	—	18.6	22.9	20.5	18.6	17.0	15.6	14.5	12.6	11.2	10.0	9.11
	MGPL	—	—	15.1	—	—	23.3	22.7	20.6	18.9	17.3	16.0	14.8	12.9	11.3	10.0	8.94
100	MGPM	—	—	38.8	—	—	33.5	37.5	33.8	30.9	28.4	26.2	24.4	21.4	19.1	17.2	15.7
	MGPL	—	—	27.1	—	—	30.6	37.9	34.6	31.8	29.3	27.2	25.3	22.1	19.5	17.3	15.5

Bore size (mm)	Non-rotating accuracy θ	
	MGPM	MGPL
12		
16	$\pm 0.08^\circ$	$\pm 0.10^\circ$
20		
25	$\pm 0.07^\circ$	$\pm 0.09^\circ$
32		
40	$\pm 0.06^\circ$	$\pm 0.08^\circ$
50		
63	$\pm 0.05^\circ$	$\pm 0.06^\circ$
80		
100	$\pm 0.04^\circ$	$\pm 0.05^\circ$

Allowable lateral load (normal load)

F(N)

Bore size (mm)	Bearing type	Stroke (mm)															
		10	20	25	30	40	50	75	100	125	150	175	200	250	300	350	400
12	MGPM	24	19	—	17	14	13	26	22	19	17	15	13	11	—	—	—
	MGPL	37	27	—	22	35	30	23	18	15	12	11	10	8	—	—	—
16	MGPM	38	31	—	27	23	21	37	32	27	24	22	20	16	—	—	—
	MGPL	54	40	—	32	54	47	35	28	23	20	17	15	12	—	—	—
20	MGPM	—	49	—	43	38	35	87	75	66	59	54	49	42	36	32	29
	MGPL	—	58	—	48	101	90	70	58	62	54	48	43	35	30	26	23
25	MGPM	—	69	—	60	54	49	116	100	88	79	71	65	55	48	43	38
	MGPL	—	82	—	68	132	118	93	77	80	70	62	55	45	38	33	29
32	MGPM	—	—	203	—	—	164	182	159	142	127	116	106	91	80	71	64
	MGPL	—	—	191	—	—	157	164	144	203	186	171	158	137	121	108	98
40	MGPM	—	—	203	—	—	164	182	159	142	127	116	106	91	80	71	64
	MGPL	—	—	190	—	—	157	163	144	203	185	171	158	137	121	108	97
50	MGPM	—	—	296	—	—	245	273	241	216	195	179	164	142	125	111	101
	MGPL	—	—	208	—	—	173	223	199	264	242	224	207	181	159	142	128
63	MGPM	—	—	296	—	—	245	273	241	216	195	179	164	142	125	111	101
	MGPL	—	—	206	—	—	171	221	196	262	240	221	205	178	157	140	126
80	MGPM	—	—	352	—	—	297	368	329	298	272	251	232	202	179	161	146
	MGPL	—	—	243	—	—	373	364	331	302	278	256	238	207	181	161	143
100	MGPM	—	—	515	—	—	445	498	450	410	377	349	325	285	254	229	208
	MGPL	—	—	360	—	—	407	503	460	423	390	362	337	294	259	230	206

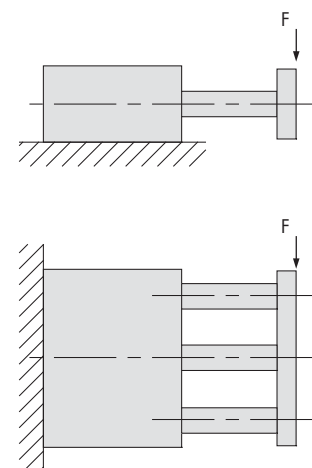

1N: Approx. 0.102kgf

Operating Range when Used as Stopper

Bore Size: 12 to 25/MGPM12 to 25 (Slide bearing)

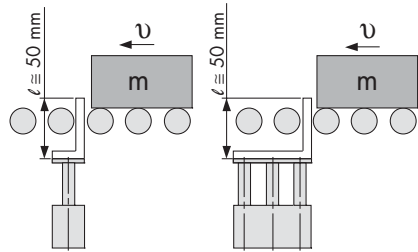

* When selecting a model with a longer l dimension, be sure to choose a bore size which is sufficiently large.

⚠ Caution
Caution on handling

Note 1) When using as a stopper, select a model with 30 stroke or less.

Note 2) Model MGPL (Ball bushing bearing) cannot be used as a stopper.

MGPM12 to 25 (Slide bearing)

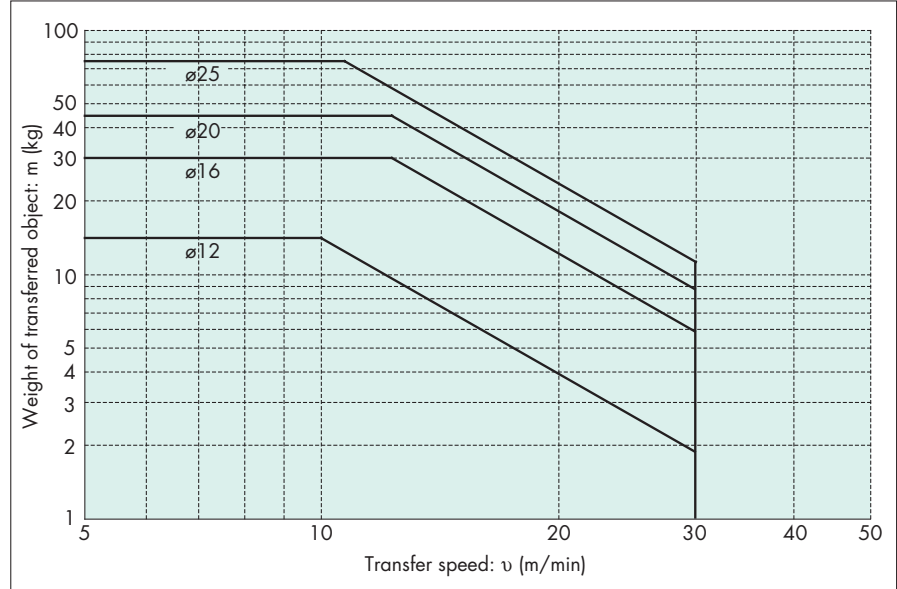

Bore Size: 32 to 100/MGPM32 to 100 (Slide bearing)

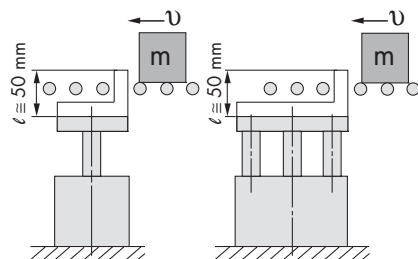

* When selecting a model with a longer l dimension, be sure to choose a bore size which is sufficiently large.

⚠ Caution
Caution on handling

Note 1) When using as a stopper, select a model with 50 stroke or less.

Note 2) Model MGPL (Ball bushing bearing) cannot be used as a stopper.

MGPM32 to 100 (Slide bearing)

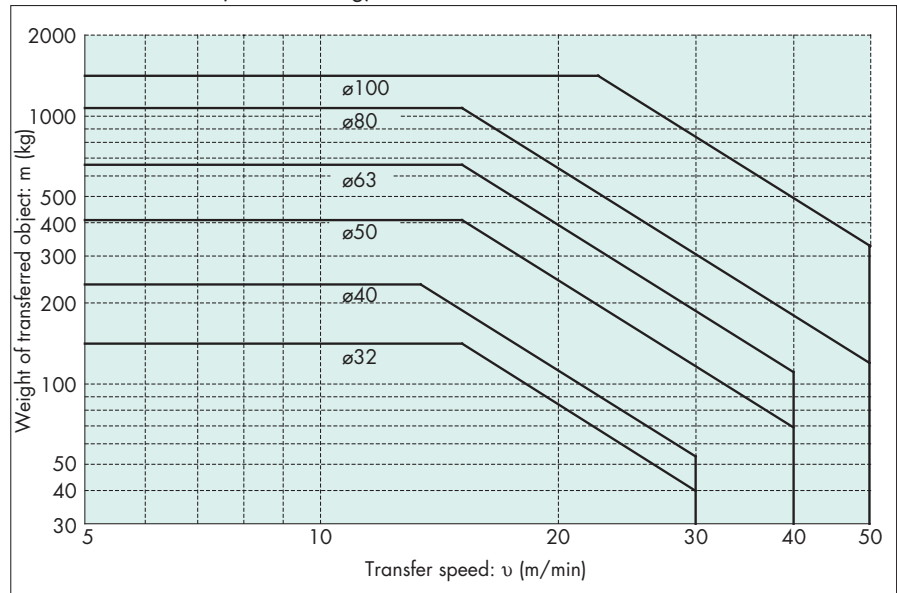

Dimensions: $\varnothing 12$ to $\varnothing 25$ /MGPM, MGPL

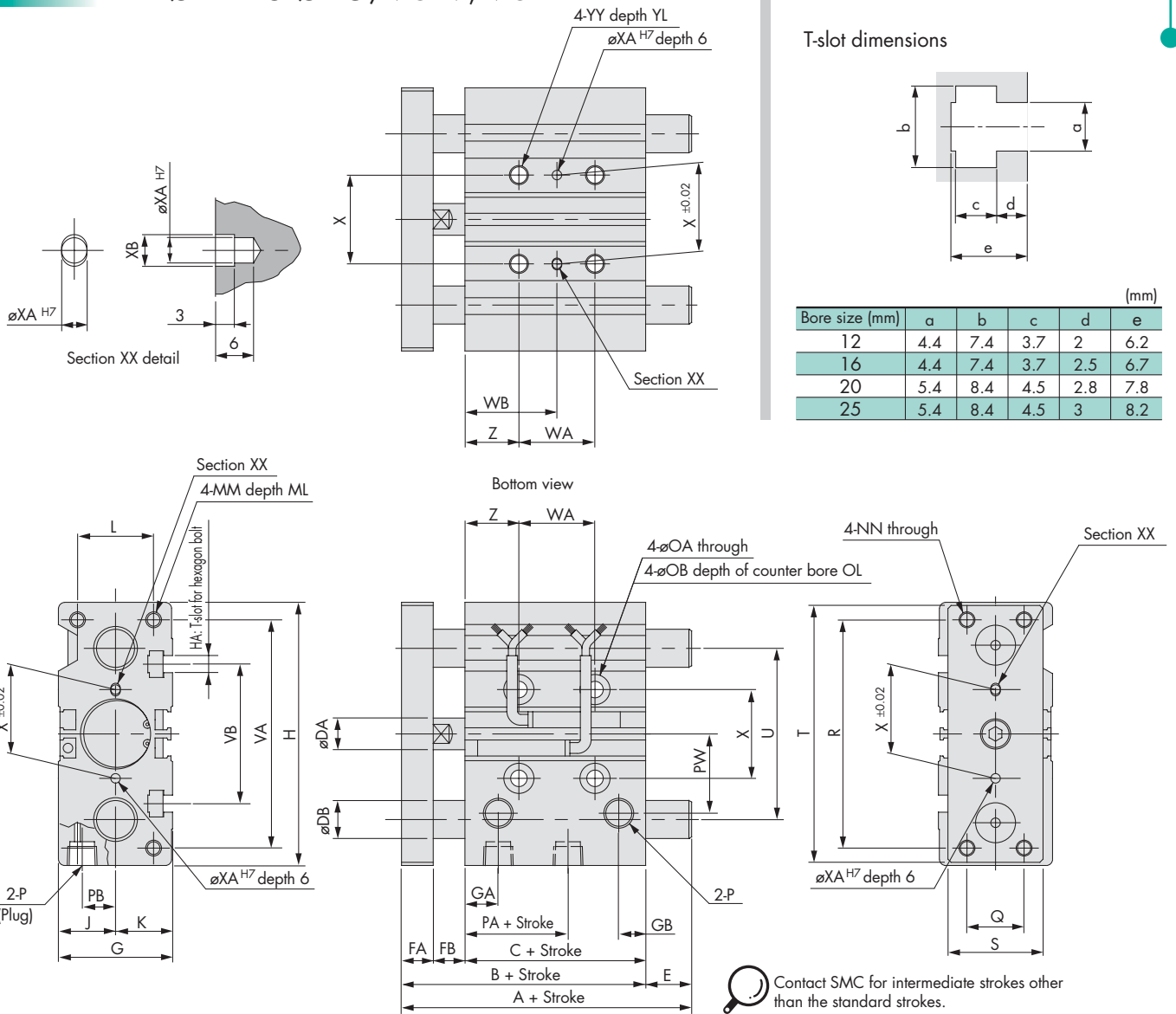

MGPM, MGPL Common dimensions

Bore size (mm)	Standard stroke (mm)	B	C	DA	FA	FB	G	GA	GB	H	HA	J	K	L	MM	ML	NN	OA	OB	OL	P	PA	PB	PW
12	10, 20, 30, 40, 50, 75, 100	42	29	6	8	5	26	11	7.5	58	M4	13	13	18	M4	10	M4	4.3	8	4.5	M5	13	8	18
16	125, 150, 175, 200, 250	46	33	8	8	5	30	11	8	64	M4	15	15	22	M5	12	M5	4.3	8	4.5	M5	15	10	19
20	20, 30, 40, 50, 75, 100, 125, 150, 175, 200, 250, 300, 350, 400	53	37	10	10	6	36	10.5	8.5	83	M5	18	18	24	M5	13	M5	5.6	9.5	5.5	1/8	12.5	10.5	25
25		53.5	37.5	12	10	6	42	11.5	9	93	M5	21	21	30	M6	15	M6	5.6	9.5	5.5	1/8	12.5	13.5	28.5

MGPM (slide bearing)/Dimensions A, DB, E (mm)

Bore size (mm)	A			DB	E		
	50st or less	Over 50st to 100st	Over 100st		50st or less	Over 50st to 100st	Over 100st
12	42	60.5	85	8	0	18.5	43
16	46	64.5	95	10	0	18.5	49

MGPL (ball bushing)/Dimensions A, DB, E (mm)

Bore size (mm)	A			DB	E		
	30st or less	Over 30st to 100st	Over 100st		30st or less	Over 30st to 100st	Over 100st
12	43	55	85	6	1	13	43
16	49	65	95	8	3	19	49

MGPM (slide bearing)/Dimensions A, DB, E (mm)

Bore size (mm)	A			DB	E		
	50st or less	Over 50st to 200st	Over 200st		50st or less	Over 50st to 200st	Over 200st
20	53	84.5	122	12	0	31.5	69
25	53.5	85	122	16	0	31.5	68.5

MGPL (ball bushing)/Dimensions A, DB, E (mm)

Bore size (mm)	A				DB	E			
	30st or less	Over 30st to 100st	Over 100st to 200st	Over 200st		30st or less	Over 30st to 100st	Over 100st to 200st	Over 200st
20	63	80	104	122	10	10	27	51	69
25	69.5	85.5	104.5	122	13	16	32	51	68.5

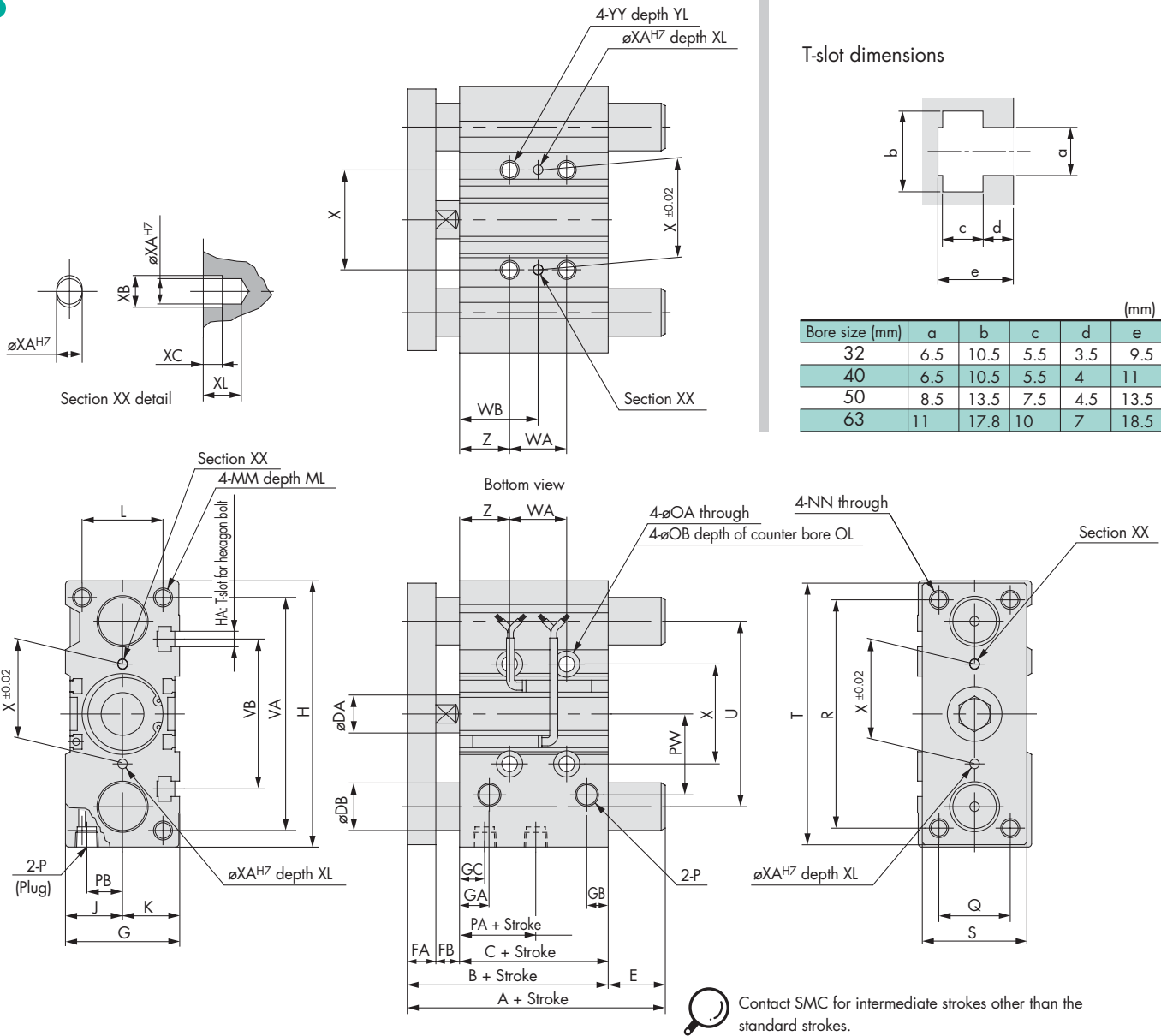
Dimensions: $\varnothing 32$ to $\varnothing 63$ /MGPM, MGPL

MGPM, MGPL Common dimensions

Bore size (mm)	Standard stroke (mm)	B	C	DA	FA	FB	G	GA	GB	GC	H	HA	J	K	L	MM	ML	NN	OA	OB	OL	P	PA	PB	PW	Q
32		59.5	37.5	16	12	10	48	12.5	9	12.5	112	M6	24	24	34	M8	20	M8	6.6	11	7.5	1/8	7	15	34	30
40	25, 50, 75, 100, 125, 150, 175, 200	66	44	16	12	10	54	14	10	14	120	M6	27	27	40	M8	20	M8	6.6	11	7.5	R1/8	13	18	38	30
50	250, 300, 350, 400	72	44	20	16	12	64	14	11	12	148	M8	32	32	46	M10	22	M10	8.6	14	9	1/4	9	21.5	47	40
63		77	49	20	16	12	78	16.5	13.5	16.5	162	M10	39	39	58	M10	22	M10	8.6	14	9	1/4	14	28	55	50

Bore size (mm)	R	S	T	U	VA	VB	WA				WB				X	XA	XB	XC	XL	YY	YL	Z		
							25st or less	Over 25st to 100st	Over 100st to 200st	Over 200st to 300st	25st or less	Over 25st to 100st	Over 100st to 200st	Over 200st to 300st										
32	96	44	110	78	98	63	24	48	124	200	300	33	45	83	121	171	42	4	4.5	3	6	M8	16	21
40	104	44	118	86	106	72	24	48	124	200	300	34	46	84	122	172	50	4	4.5	3	6	M8	16	22
50	130	60	146	110	130	92	24	48	124	200	300	36	48	86	124	174	66	5	6	4	8	M10	20	24
63	130	70	158	124	142	110	28	52	128	200	300	38	50	88	124	174	80	5	6	4	8	M10	20	24

MGPM (slide bearing)/Dimensions A, DB, E

Bore size (mm)	A			DB	E		
	50st or less	Over 50st to 200st	Over 200st		50st or less	Over 50st to 200st	Over 200st
32	97	102	140	20	37.5	42.5	80.5
40	97	102	140	20	31	36	74
50	106.5	118	161	25	34.5	46	89
63	106.5	118	161	25	29.5	41	84

MGPL (ball bushing)/Dimensions A, DB, E

Bore size (mm)	A				DB	E			
	50st or less	Over 50st to 100st	Over 100st to 200st	Over 200st		50st or less	Over 50st to 100st	Over 100st to 200st	Over 200st
32	81	98	118	140	16	21.5	38.5	58.5	80.5
40	81	98	118	140	16	15	32	52	74
50	93	114	134	161	20	21	42	62	89
63	93	114	134	161	20	16	37	57	84



CAD CD-ROM AVAILABLE



 CATALOGUE **ES20-117C** AVAILABLE

PDF AVAILABLE ONLINE

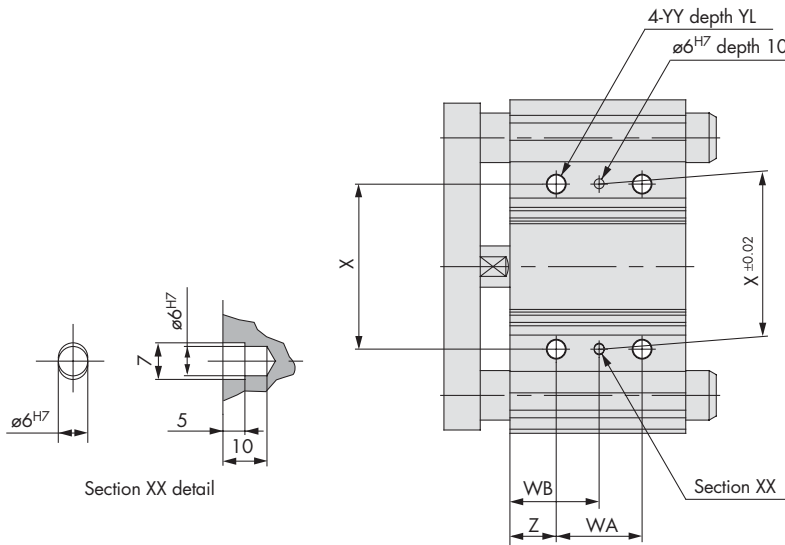
Dimensions: $\varnothing 80$, $\varnothing 100$ /MGPM, MGPL

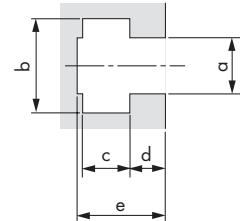

T-slot dimensions



Bore size (mm)	a	b	c	d	e
80	13.3	20.3	12	8	22.5
100	15.3	23.3	13.5	10	30

Actuators

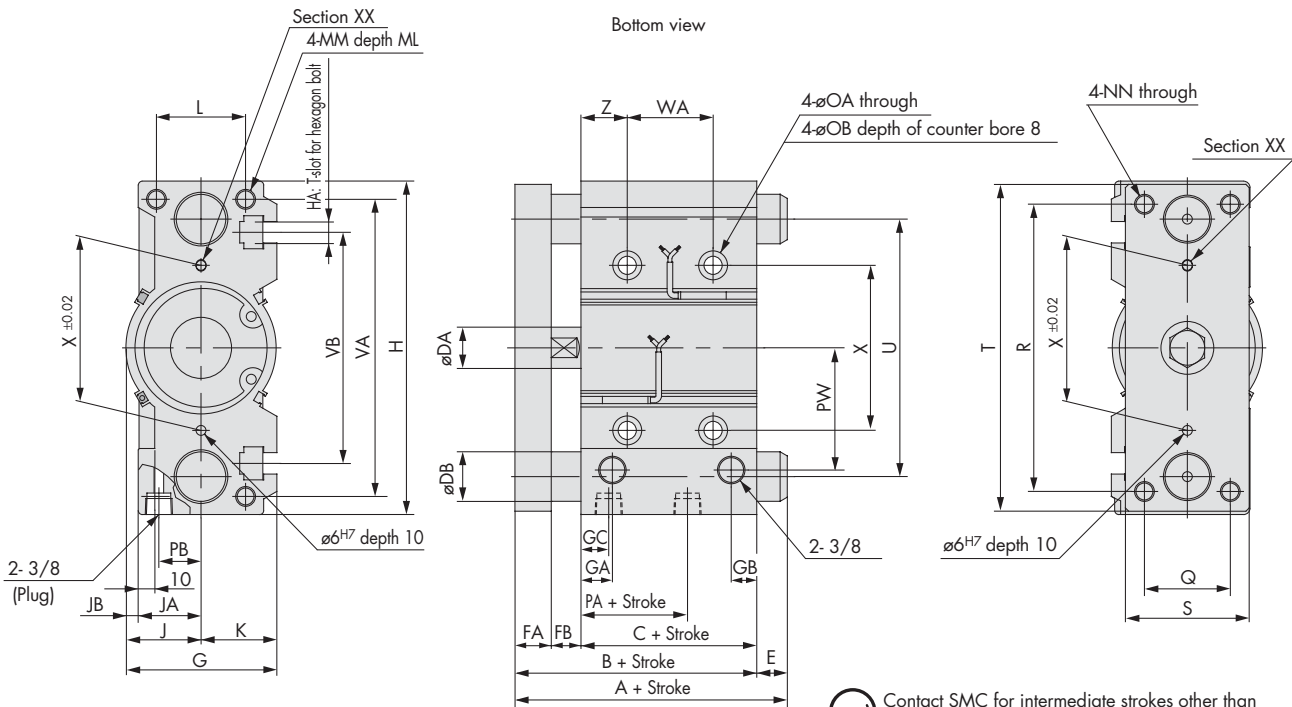

Contact SMC for intermediate strokes other than the standard strokes.

MGPM, MGPL Common dimensions

Bore size (mm)	Standard stroke (mm)	B	C	DA	FA	FB	G	GA	GB	GC	H	HA	J	JA	JB	K	L	MM	ML	NN	OA	OB	PA	PB	PW	Q	R
80	25, 50, 75, 100, 125, 150, 175, 200	96.5	56.5	25	22	18	91.5	19	15.5	14.5	202	M12	45.5	38	7.5	46	54	M12 x 1.75	25	M12	10.6	17.5	14.5	25.5	74	52	174
100	250, 300, 350, 400	116	66	30	25	25	111.5	23	19	18	240	M14	55.5	45	10.5	56	62	M14 x 2.0	31	M14	12.5	20	17.5	32.5	89	64	210

Bore size (mm)	S	T	U	VA	VB	WA					WB					X	YY	YL	Z
						25st or less	Over 25st to 100st	Over 100st to 200st	Over 200st to 300st	Over 300st	25st or less	Over 25st to 100st	Over 100st to 200st	Over 200st to 300st	Over 300st				
80	75	198	156	180	140	28	52	128	200	300	42	54	92	128	178	100	M12	24	28
100	90	236	188	210	166	48	72	148	220	320	35	47	85	121	171	124	M14	28	11

MGPM (slide bearing)/Dimensions A, DB, E (mm)

Bore size (mm)	A			DB	E		
	50st or less	Over 50st to 200st	Over 200st		50st or less	Over 50st to 200st	Over 200st
80	115	142	193	30	18.5	45.5	96.5
100	137	162	203	36	21	46	87

MGPL (ball bushing)/Dimensions A, DB, E (mm)

Bore size (mm)	A				DB	E			
	25st or less	Over 25st to 50st	Over 50st to 200st	Over 200st		25st or less	Over 25st to 50st	Over 50st to 200st	Over 200st
80	109.5	130	160	193	25	13	33.5	63.5	96.5
100	121	147	180	203	30	5	31	64	87